



Republika ng Pilipinas  
**NATIONAL COUNCIL ON DISABILITY AFFAIRS**

**BOARD RESOLUTION NO. 12  
SERIES OF 2024**

**APPROVAL OF THE NCDA's PROPOSED ORGANIZATIONAL STRUCTURE  
FOR FY 2026**

**WHEREAS**, Executive Order No. 709, entitled "Redefining the Functions and Organizational Structure of the National Council for the Welfare of Disabled Persons which is Renamed as the National Council on Disability Affairs and Attached to the Office of the President, and Amending for the Purpose Executive Order 676 (2007) and Executive Order 232 (1987)" was approved in February 2008;

**WHEREAS**, The Rationalization Plan (RatPlan) of the National Council on Disability Affairs (NCDA) was approved through Executive Order No. 366 on 05 November 2010. The NCDA RatPlan enforces the strategic review of agency operations and organizations to improve public service delivery;

**WHEREAS**, the number of registered Persons with Disabilities (PWDs) in the Philippine Registry of Persons with Disabilities (PRPWD) has grown exponentially from 128,000 in 2021 to 1,847,015 as of November 2024;

**WHEREAS**, there are 434 Persons with Disabilities Affairs Offices (PDAOs) and 1,178 Focal Persons in the country which the NCDA collaborates with to ensure that government services are within the reach of PWDs

**WHEREAS**, the current number of permanent positions (61) in the NCDA, is already too small considering the latitude of the work being conducted to all its stakeholders up to the national level

**WHEREAS**, the NCDA has applied for Commissioning through House Bill 7717 in the 19<sup>th</sup> Congress – An Act "Reorganizing the National Council on Disability Affairs into the National Commission on Disability Affairs, Defining Its Powers and Functions, Appropriating Funds Therefor" and Senate Bill 108 titled "Reorganizing the National Council on Disability Affairs into the National Commission on Disability Affairs, Defining Its Powers and Functions, Appropriating Funds Therefor, and for Other Purposes" or the "National Commission on Disability Affairs Act";

**WHEREAS**, in view of the growing stakeholder population and the expansion & improvement of programs and services, there is an urgent and compelling need to strengthen and build-up the organizational structure of the National Council on Disability Affairs (NCDA). This is essential to effectively respond to the increasing demands for specialized staffing and resources to ensure the efficient deployment and sustainability of these programs and services. By fortifying its structure, the NCDA can better address the diverse and evolving needs of the Persons with

Disabilities (PWDs), enhance coordination with stakeholders, and fulfill its critical mandate of promoting inclusion, accessibility, and equal opportunities for all. Strengthening the NCDA's organizational capacity is a vital step toward meeting the growing expectations of stakeholders and advancing national and international commitments to disability rights and development;

**WHEREAS**, the NCDA conducted a Workforce Planning and drafted an organizational structure with target implementation in FY 2026 to be proposed to the Department of Budget and Management (DBM) for approval;

**WHEREAS**, NCDA Board Resolution No. 4 S. 2024, "A Resolution Delegating Approval of Succeeding Council Resolutions and/or its Equivalent to the National Council on Disability Affairs Chairperson and Designated Officials, duly authorize the NCDA Chairperson and the NCDA Executive Director to sign this Resolution for and on behalf of the NCDA Governing Board;

**NOW THEREFORE, RESOLVED**, as it is hereby resolved, that in view of the recommendation of the Secretariat, the NCDA Governing Board approves the proposed Organizational Structure for FY 2026.

**APPROVED** held this \_\_\_\_ day of \_\_\_\_ 2024 via *ad referendum*.

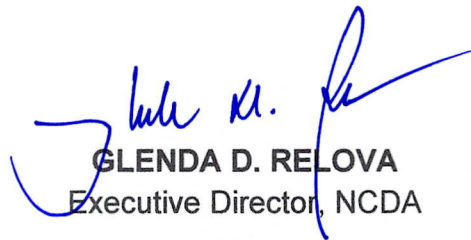

**GLEND A. RELOVA**  
Executive Director, NCDA



**REX GATCHALIAN**  
DSWD Secretary & Chairperson, NCDA

27 DEC 2024



## CERTIFICATION

**This is to certify that:**

1. The National Council on Disability Affairs (NCDA) is composed of the Governing Board and a Secretariat Office;
2. The NCDA Secretariat holds office at the NCDA Building Isidora St. Brgy. Holy Spirit, Quezon City;
3. I am presently the Board Secretary of the NCDA Secretariat Office;
4. I am the custodian of the records of the NCDA Governing Board, including the Minutes of Meetings and Resolutions;
5. NCDA Board Resolution No. 12 Series of 2024 entitled "Approval of the NCDA's Proposed Organizational Structure for Fiscal Year 2026" was unanimously approved and adopted;
6. The foregoing resolution has been signed by NCDA Executive Director Glenda D. Relova and NCDA Chairperson and DSWD Secretary Rex Gatchalian upon authority of the NCDA Governing Board Members;
7. The aforesaid resolution has not been altered, modified nor revoked and the same is now in full force and effect;
8. I am executing this Certification for whatever legitimate purpose this may serve.

IN WITNESS WHEREOF, I have hereunto affixed my signature this \_\_\_\_ day of \_\_\_\_\_  
2024, Quezon City.

  
**PRECIOUS KEITCH P. HORVIDALLA**  
Board Secretary III  
NCDA Secretariat Office

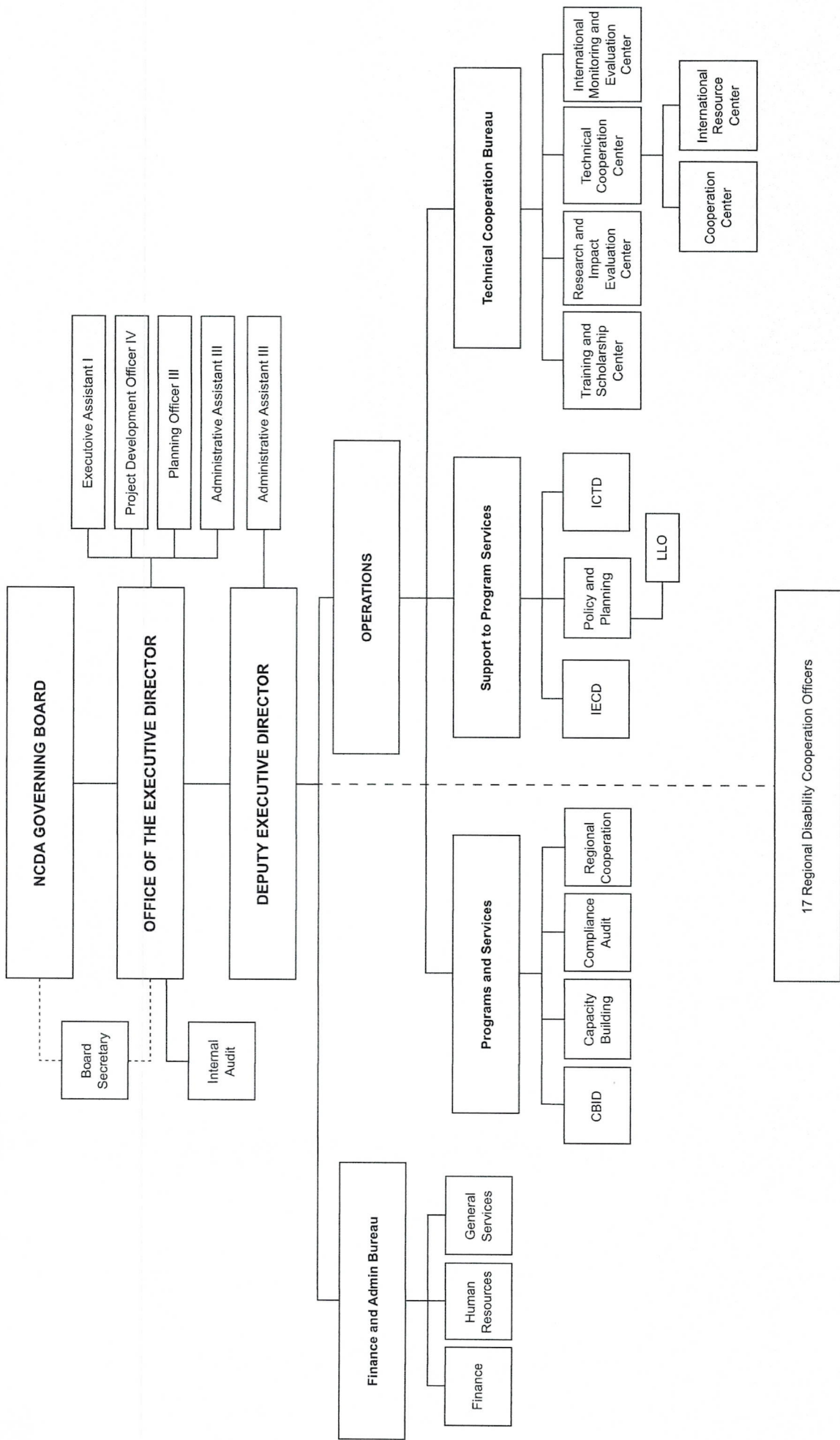

Finance and Admin Bureau

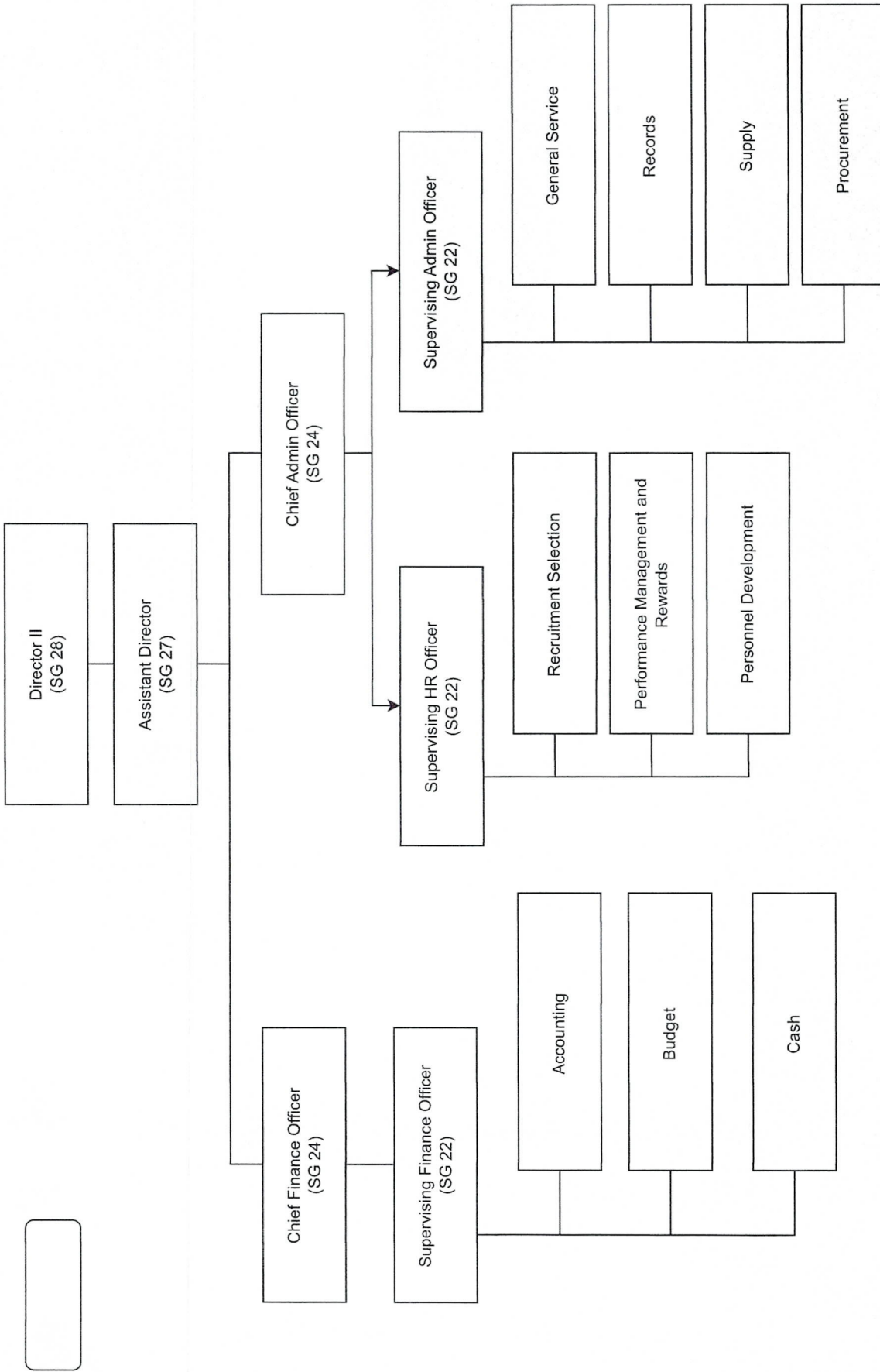

**Finance**

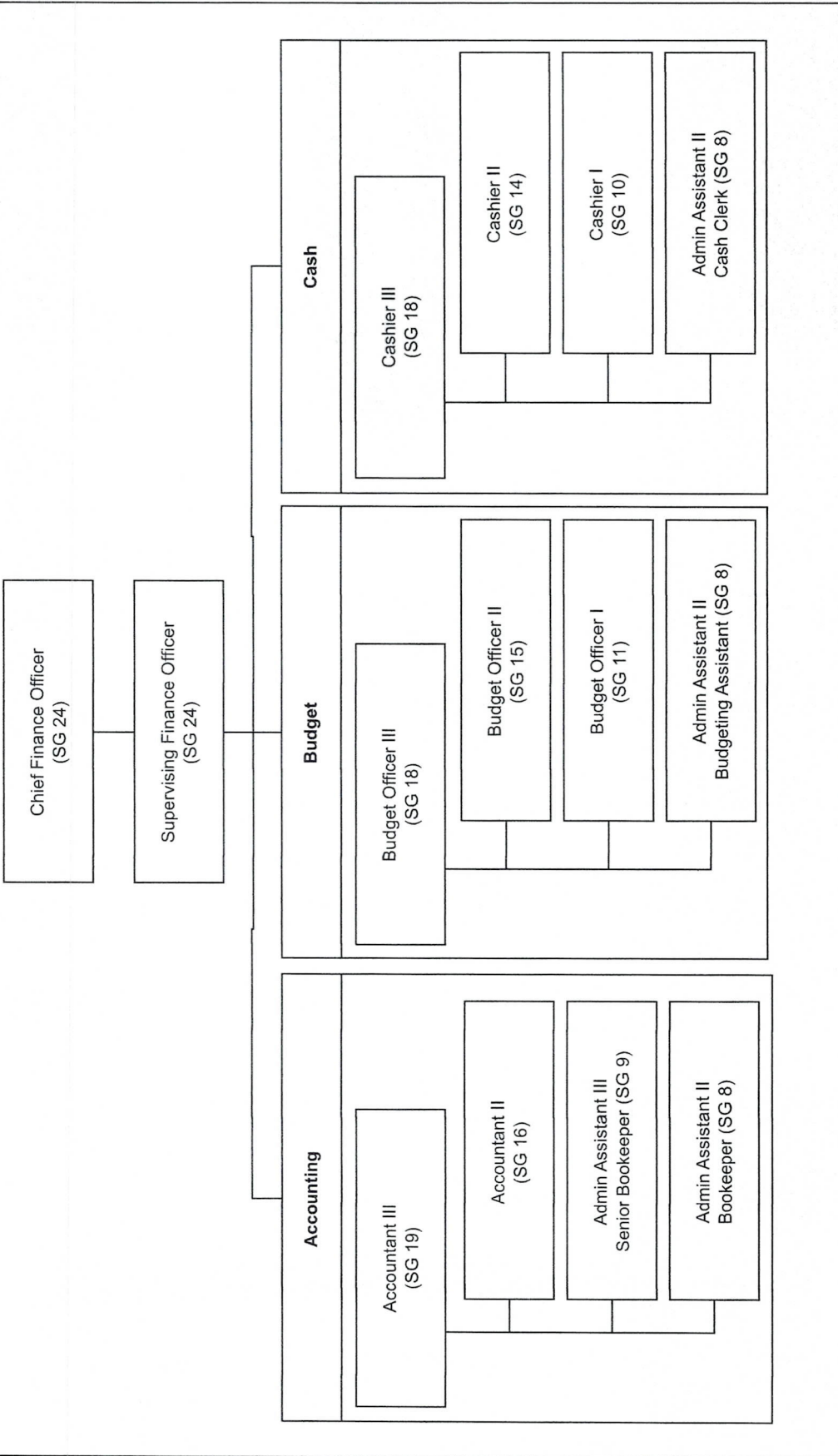

Chief Adm  
(SG

Supervising HR Officer  
HRMO IV (SG 22)

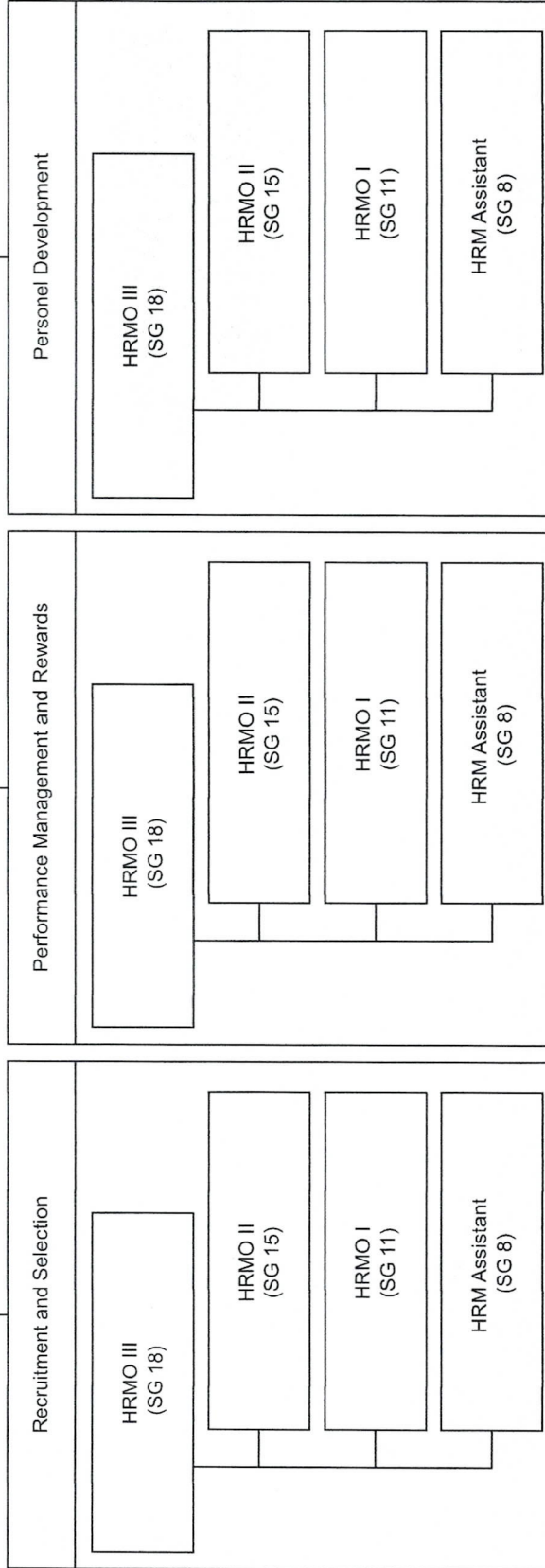

ive Division

Admin Officer  
(SG 24)

Supervising Admin Officer  
Admin Officer IV (SG 22)

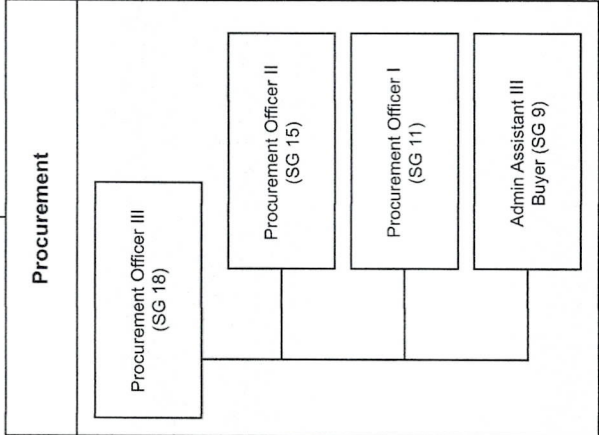
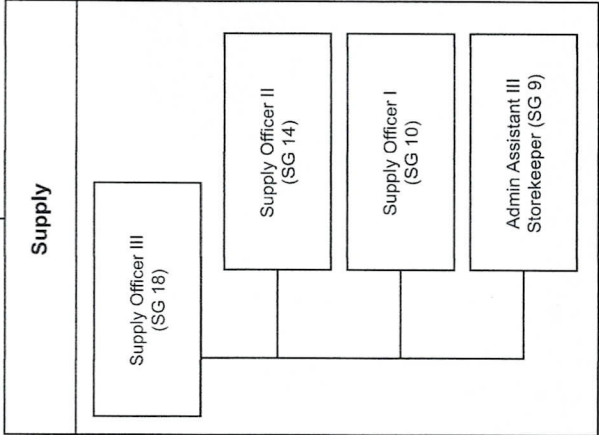
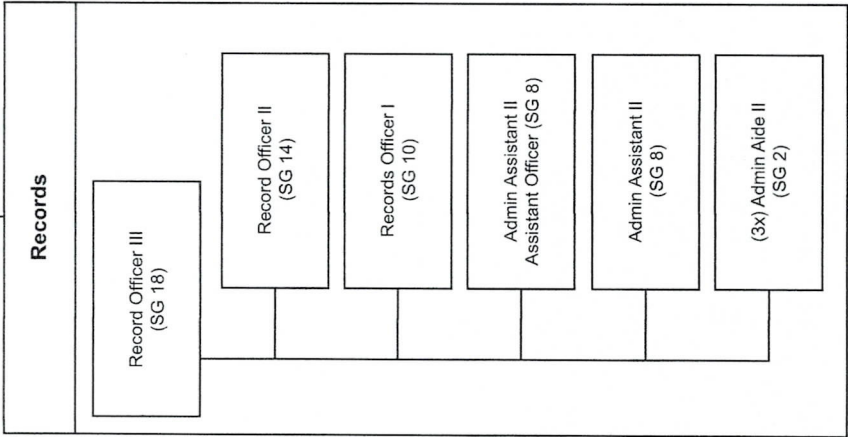
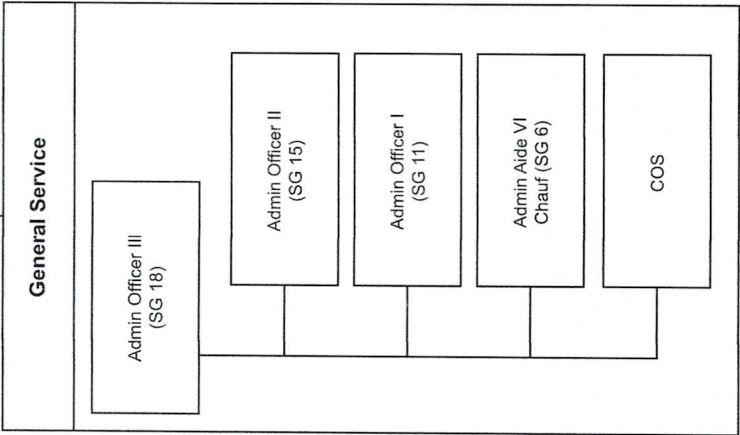



OPERATIONS

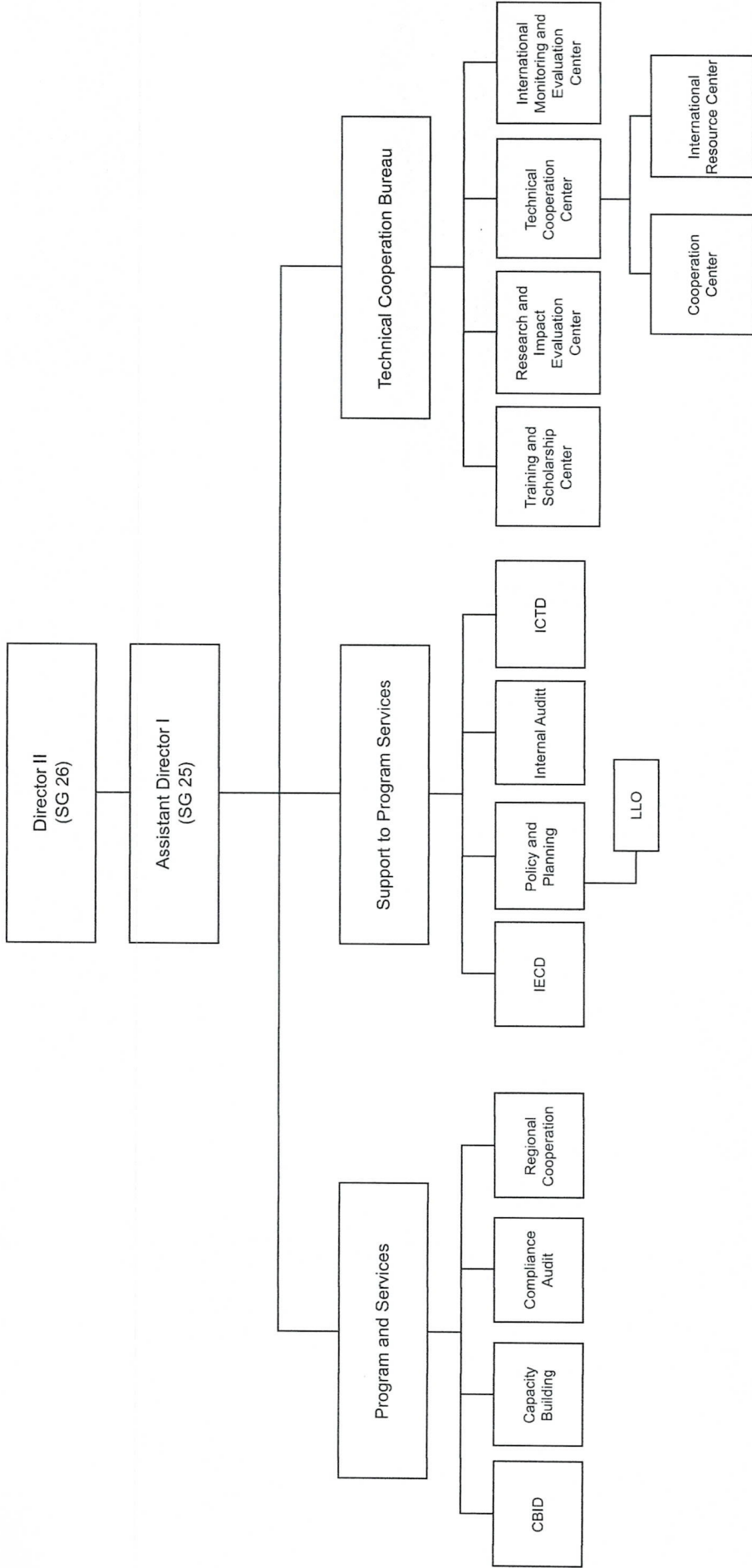

**Programs and Services  
(RPC)**

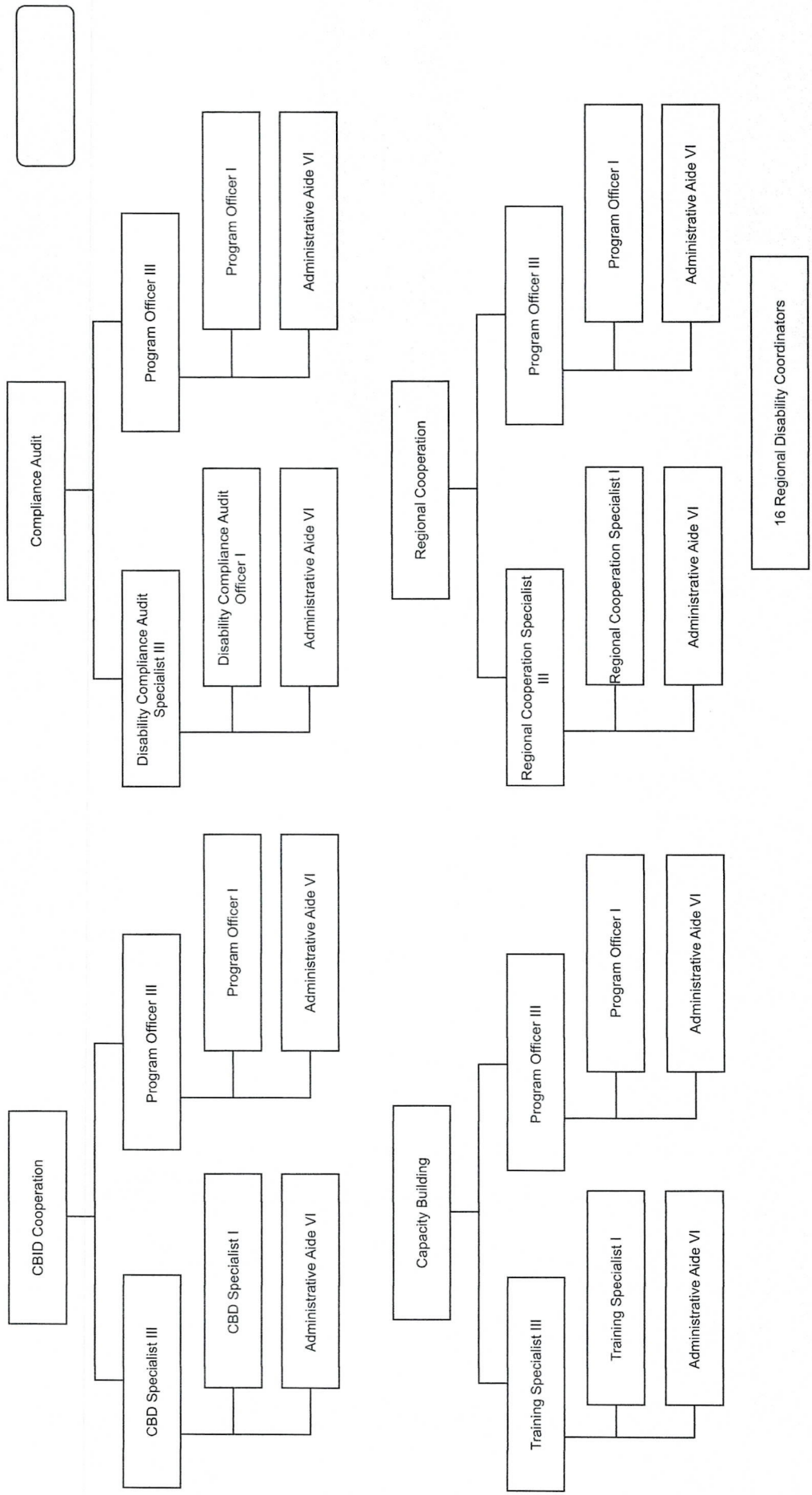

Advocacy and Strategic Communications

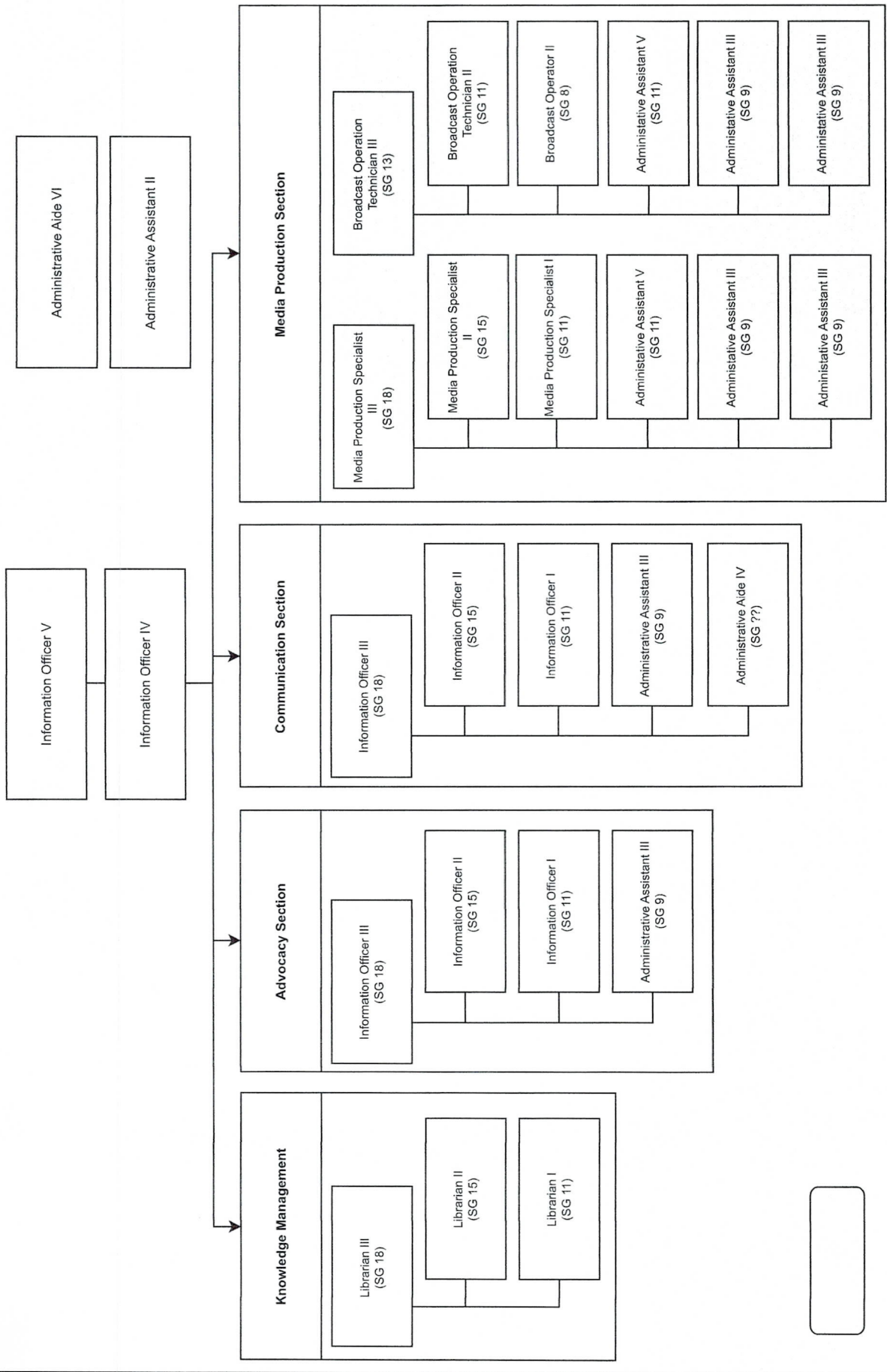

Management Information System Division



Information Technology Officer III  
(SG 24)

Administrative Assistant III  
(SG 9)

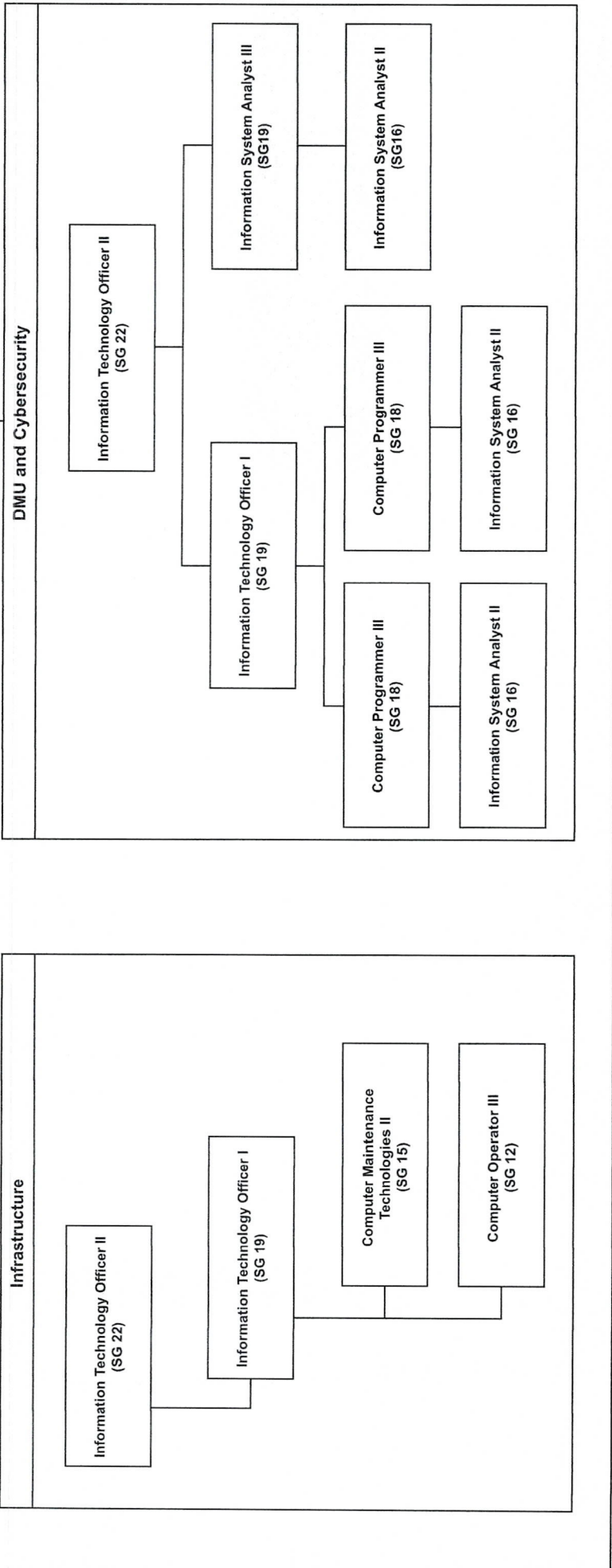

Technical Cooperation Bureau

